



**Material:** Mild steel  
**Finish:** Zinc plated and yellow passivated

**PLUS POINTS**

- Suitable for use in mild steel or softer materials
- Serrated to prevent rotation
- Manufactured to suit different thicknesses of material

**HEAVY DUTY RIVET BUSHES**

Designed to provide a neat and reliable threaded fastener for all types of sheet metal. Heavy Duty Rivet Bushes can be produced in different materials or finishes on request.

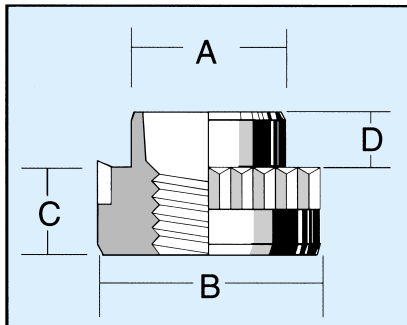

A hole is drilled or punched to our recommended size

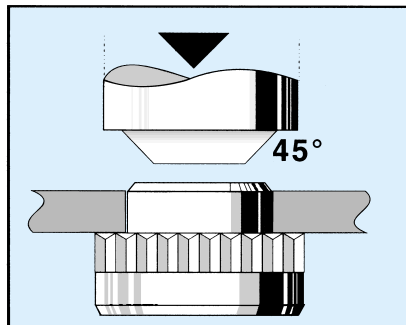

Locate knurled spigot in hole so that shoulder resting on surface of parent material and knurl protrudes through to the other side

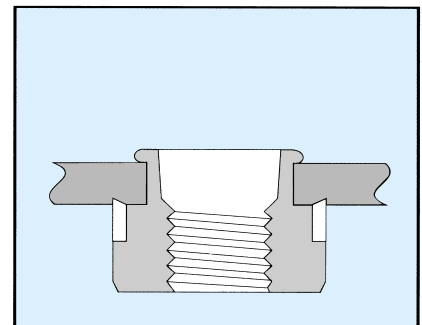

Support bush from base and drive punch into counterbore riveting the spigot over onto the parent material until almost flush

Thread Size	Part No.	Sheet thickness up to	A Max.	B Max.	C ±0.15	D ±0.1	Hole size +0.1 -0.0
M3	P1950	1	5.74	7.92	3.2	1.78	5.8
M3	P1956	1.5	5.74	7.92	3.2	2.39	5.8
M4	P1951	1	5.74	7.92	3.2	1.78	5.8
M4	P1957	1.5	5.74	7.92	3.2	2.39	5.8
M5	P1952	1.25	7.09	11.1	3.89	2.16	7.14
M5	P1958	2.25	7.09	11.1	3.89	3.2	7.14
M6	P1953	1.5	8.69	12.7	4.72	2.34	8.71
M6	P1959	2.25	8.69	12.7	4.72	3.2	8.71
M8	P1954	2	11.05	14.29	6.35	2.92	11.1

All Dimensions are in millimetres