



Material: Mild steel
Finish: Zinc plated and yellow passivated

STANDARD RIVET BUSHES

Designed to provide a neat and reliable fastener for all types of sheet metal. Standard Rivet Bushes can be produced in different materials or finishes on request.

PLUS POINTS

- Suitable for use in mild steel or softer materials
- Serrated to prevent rotation
- Manufactured to suit different thicknesses of material

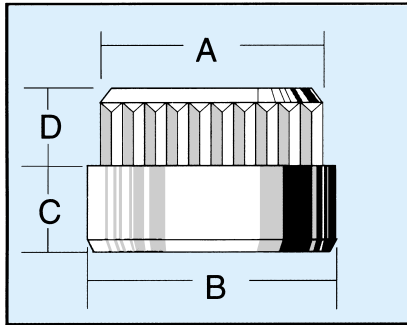

A hole is drilled or punched to our recommended size

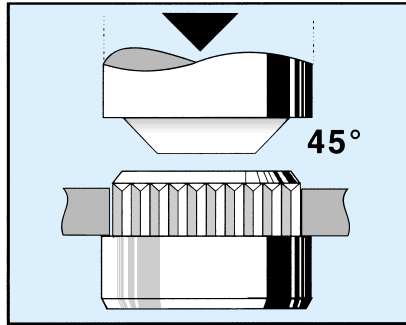

Locate knurled spigot in hole so that shoulder is resting on surface of parent material and knurl protrudes through to the other side

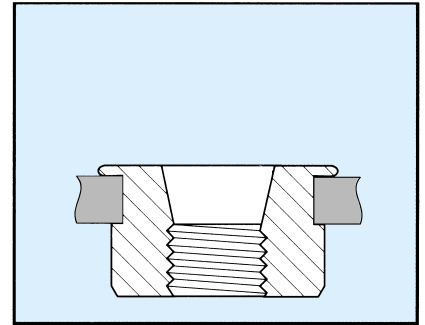

Support bush from base and drive punch into counterbore riveting the spigot over onto the parent material until almost flush

Thread size	Part No.	A Max.	B Max.	C ±0.15	Hole size +0.1 -0.0
M2.5	P1800	4.34	5.54	3.12	4.4
M3	P1801	5.74	7.14	3.76	5.8
M4	P1803	5.74	7.14	3.76	5.8
M5	P1804	7.09	8.71	4	7.14
M6	P1805	8.69	10.31	5.28	8.71
M8	P1806	11.05	12.7	5.28	11.10

Sheet Thickness	Below 20SWG	Up to 18/20SWG	Up to 16/17SWG	Up to 14/15SWG	Up to 12/13SWG
	<0.9	1.2	1.6	2	2.6
D ±0.1	1.32	1.73	2.18	2.67	3.18

When ordering, please quote the part number and the required "D" dimension e.g. P1800 x 18/20SWG

All Dimensions are in millimetres